

FITTING INSTRUCTION

Clamp mark in acc. with		Cables joining
ISO	PN	
1	L	Left directional lights
2	+	Rear fog lights
3	31	Ground
4	R	Right directional lights
5	58R	Right side parking lights
6	54	Stoplights
7	58L	Left side parking lights

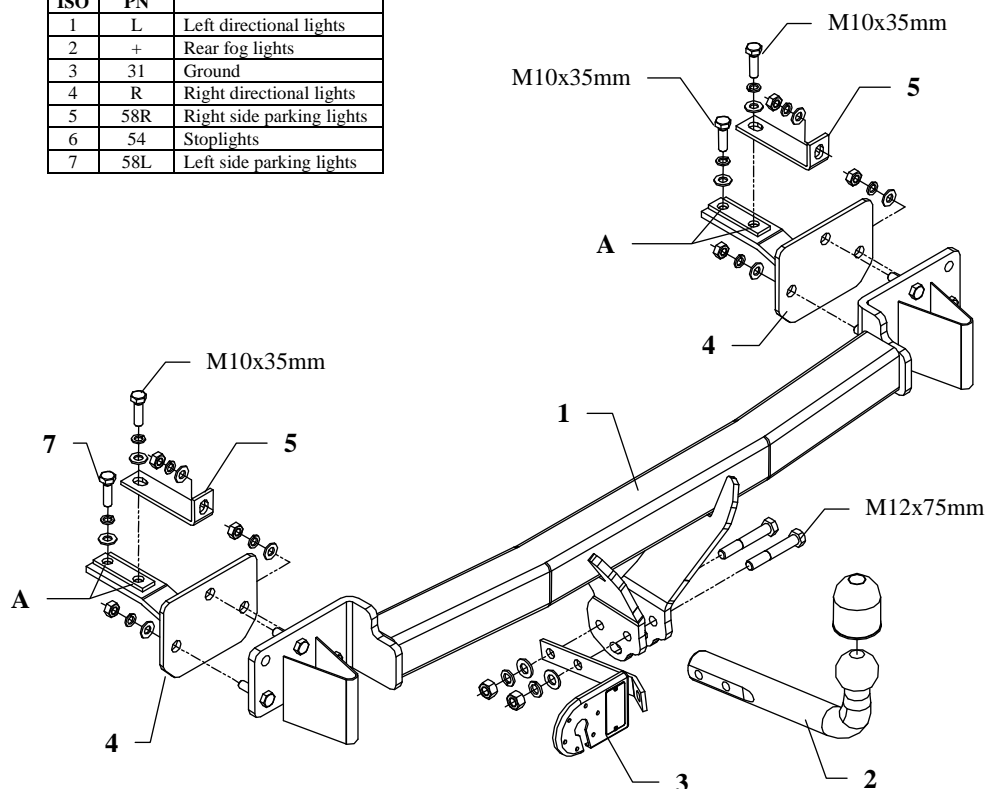

This towbar is designed to assembly in following cars:
BMW SERIE 5 TOURING (ESTATE), produced since 02.1997 till 01.2004, catalogue number **B09** and is prepared to tow trailers max total weight **2200kg** and max vertical load **90 kg**.

From manufacturer

Thank you for buying our product. Their reliability has been confirmed in many tests. Reliability of towbar depends also on correct assembly and right operation. For this reasons we kindly ask to read carefully this instruction and apply to hints.

The towbar should be install in points described by a car producer.

The instruction of the assembly

1. Inside trunk disassemble side cover plates of wheel arch. Take out a spare wheel and dismount cover of spare wheel recess.
2. Disassemble rear bumper:
 - unscrew 6 nuts M8 inside trunk on rear panel and disconnect 3 clips around each wheel arch
 - unscrew bolts fastening the bumper on left and right side (inside trunk).
3. Remove the shock absorbers from the bumper (not used any more).
4. Remove the lightweight metal frame, polystyrene filler and the heat shield (if fitted). Saw the centre section from the lightweight metal frame along the pre-punched dotted line (fig. 3).
5. Cut out a part of the reinforcing ridge on the inside of the bumper (fig. 4). Next cut out rectangular holes in central part of the bumper (see fig. 5). **Be careful!** Do not damage the bumper while drilling.
6. Using fitted template cut two elements plastic and paste it on rear wall, on the left and right side of bodywork according to figure 2.
7. Put side brackets (pos. 4) to holes in bodywork, see figure 2. Put bend fish-plates (pos. 5) in the trunk and fix loosely with side brackets (pos. 4) through holes pos. A using four bolts M10x35mm (pos. 7).
8. Place towbar in the lightweight metal frame and fasten it at the shock absorber points using original attaching accessories. All unit put to the bumper and replace the heat shield (if fitted).
9. Fix tow-ball (pos. 2) with socket plate (pos. 3) using bolts M12x75mm (pos. 6) from equipment.
10. Install bumper with towbar unit using nuts M10. Reassemble parts indicated in point 1.
11. Fix tight all bolts according to the torque shown in the table.
12. Connect electric wires of 7-poles socket according to the instruction of the car. (Recommend to make at authorized service station).
13. Complete paint layer damaged during installation.

Torque settings for nuts and bolts (8,8):	
M 8 - 25 Nm	M 10 - 55 Nm
M 12 - 85 Nm	M 14 - 135 Nm









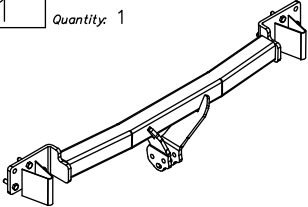
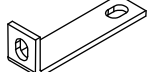

NOTE

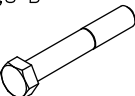
After install the towbar you should get adequate note in registration book (at authorised service station). The car should be equipped with:

- Indicators
- Tow mirrors

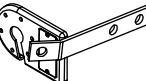
After 1000km check all bolts and nuts. The ball of towbar must be always kept clear and conserve with a grease.

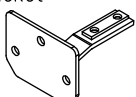
Towbar equipment:

Pos. 1	Name: Main bar Quantity: 1	Pos. 5	Name: Bend fish-plate Quantity: 2	Pos. 10	Name: Plain washer Quantity: 2 Dim.: ϕ 13 mm
					
		Pos. 6	Name: Bolt 8,8 B Quantity: 2 Dim.: M12x75mm	Pos. 11	Name: Plain washer Quantity: 10 Dim.: ϕ 10,5 mm
					
Pos. 2	Name: Tow ball Quantity: 1	Pos. 7	Name: Bolt 8,8 B Quantity: 4 Dim.: M10x35mm	Pos. 12	Name: Spring washer Quantity: 2 Dim.: ϕ 12,2 mm
					
Pos. 3	Name: Socket plate Quantity: 1	Pos. 8	Name: Nut 8 B Quantity: 2 Dim.: M12	Pos. 13	Name: Spring washer Quantity: 10 Dim.: ϕ 10,2 mm
					
Pos. 4	Name: Side bracket Quantity: 2	Pos. 9	Name: Nut 8 B Quantity: 6 Dim.: M10	Pos. 14	Name: Ball cover Quantity: 1
					



PPUH AUTO-HAK S.J.

Produkcja Haków Holowniczych
Henryk & Zbigniew Nejman
76-200 SŁUPSK ul. Słoneczna 16K
tel/fax (059) 8-414-414; 8-414-413
E-mail: office@autohak.com.pl
www.autohak.com.pl

Towing hitch (without electrical set)

Class: **A50-X** Cat. no. **B09**

Designed for:

Manufacturer: **BMW**

Model: **series 5**

Type: **Touring (ESTATE)**

produced since 02.1997 till 01.2004

Technical data:

D-value: 11,4 kN

maximum trailer weight: **2200 kg**

maximum vertical cup load: **90 kg**

Approval number according to Directive 94/20/EC: e20*94/20*0092*01

Foreword

This towbar is designed according to rules of safety traffic regulations. The towing hitch is a safety component and can be install only by qualified personnel. Any alteration or conversion of the towing hitch is prohibited and would lead to cancellation of design certification. Remove insulating compound and underseal from vehicle (if present) in the area of the matting surfaces of the towing hitch.

The vehicle manufacturer's specifications regarding trailer load and max. vertical cup load are decisive for driving whereat values for the towing hitch cannot be exceeded.

D-value formula:

$$\frac{\text{Max trailer weight [kg]} \times \text{Max vehicle weight [kg]}}{\text{Max trailer weight [kg]} + \text{Max vehicle weight [kg]}} \times \frac{9,81}{1000} = D \text{ [kN]}$$